

REV	DESCRIPTION	DRAWN	DATE

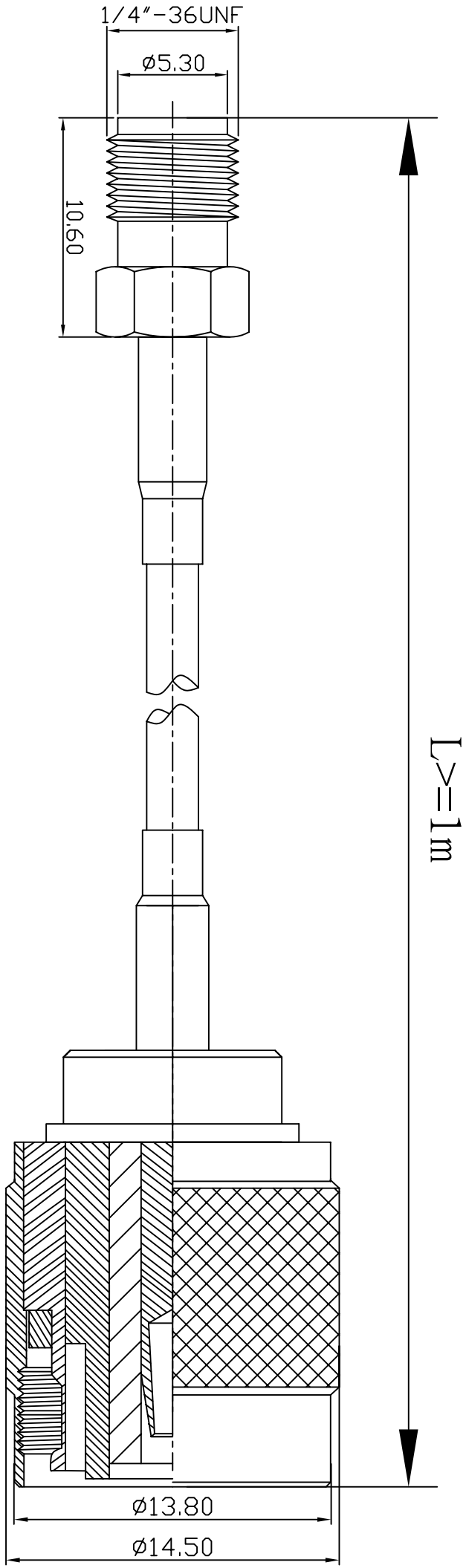

$L \geq 1 \text{ m}$

NO	Description	Qty	Material	Finish
3	TNC-1501-2-L-RP-TGN	1	BRASS	GOLD
2	RG174/RG316/LLC100	1		
1	SMA-1011-1-L-TGC	1	BRASS	GOLD

UNLESS OTHERWISE SPECIFIED		*MAJOR DIMENSION	
1 REMOVE ALL BURRS		UNLESS OTHERWISE	
2 BREAK ALL CORNERS & EDGES CO.15 MAX.		NOTED TOLERANCES	
3 CHAMFER 1:1 & LAST THREADS 45°		0.5-6 = ±0.2	
4 DIAMETERS ON COMMON CENTERS TO BE CONCENTRIC WITHIN DIMENSIONS ARE AFTER PLATING.		6-30 = ±0.4	
		30-120 = ±0.6	
		120-315 = ±1.0	
		ANGLES = ±1°	

APPROVED	CHECKED	DRAWN	DRAWN DATE
		ARNQ	03/06/23

華耀科技有限公司 <i>Hua Yao Technologies co.,Ltd</i>	
TITLE	SMA1011-TNC1501
DRAWING NO.	15012R/174/316/100/10111-AL
REV	A
FILE NO.	D:\DWG\SMA1011-TNC1501\15012R\174\316\100\10111-AL